

DRAG-A-BOX
BRAND
MATERIAL SPREADERS

MODEL CE 7-12

PARTS MANUAL

BY
J. PYOTT & ASSOCIATES

This is the PARTS MANUAL. In this manual you will find pictures and descriptions of the standard parts used to assemble the MATERIAL SPREADER and the components used to mount the MATERIAL SPREADER to a standard dump truck. It is important that you study this manual before attempting to install or operate the MATERIAL SPREADER.

This is a list of the standard parts of the MATERIAL SPREADER you will be using to operate it properly.

PRIMARY PART LIST & DESCRIPTION

- 1) **SCREED**
- 2) **JACK ADJUSTMENT BAR, REAR**
- 3) **EXTENSION JACK, REAR**
- 4) **LIFT JACK**
- 5) **SIDE HANDLE**
- 6) **SKID**
- 7) **TOW PLATE**
- 8) **LIFT BRACKET, REAR**
- 9) **LIFT BRACKET, FRONT**
- 10) **FRONT ADJUSTABLE PLATE**
- 11) **EXTENSION JACK, FRONT**
- 12) **JACK ADJUSTMENT BAR, FRONT**
- 13) **IDENTIFICATION TAG**
- 14) **REAR HANDLE**
- 15) **SCREED HEIGHT GAUGE**
- 16) **REAR ADJUSTMENT PLATE**
- 17) **BOLT, REAR ADJUSTMENT PLATE**
- 18) **BOLT, FRONT ADJUSTMENT PLATE**
- 19) **PIN, REAR EXTENSION JACK**
- 20) **PIN, FRONT EXTENSION JACK**

This is a list of the standard parts of the TRUCK MOUNTING ASSEMBLY you will be using to attach the MATERIAL SPREADER to a standard dump truck.

- A) **TRUCK MOUNTING BRACKET ASSEMBLY**
- B) **PULL BAR**

The OPERATION MANUAL will go into detail about the components of the MATERIAL SPREADER, and the INSTALLATION MANUAL will explain all of the components of the TRUCK MOUNTING ASSEMBLY.

**MATERIAL SPREADER
MODEL CE 7-12**

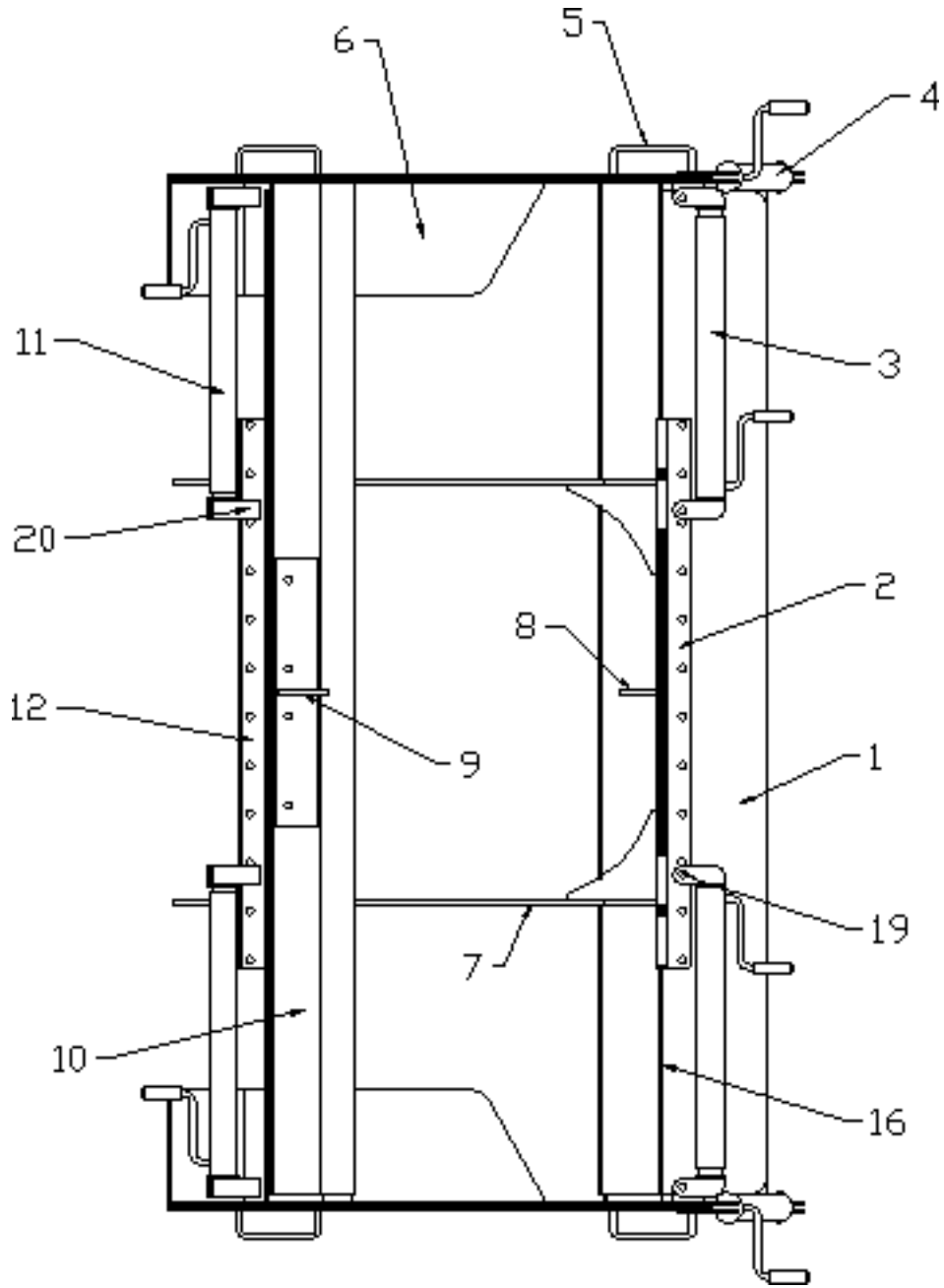

TOP VIEW



**MATERIAL SPREADER
MODEL CE 7-12**

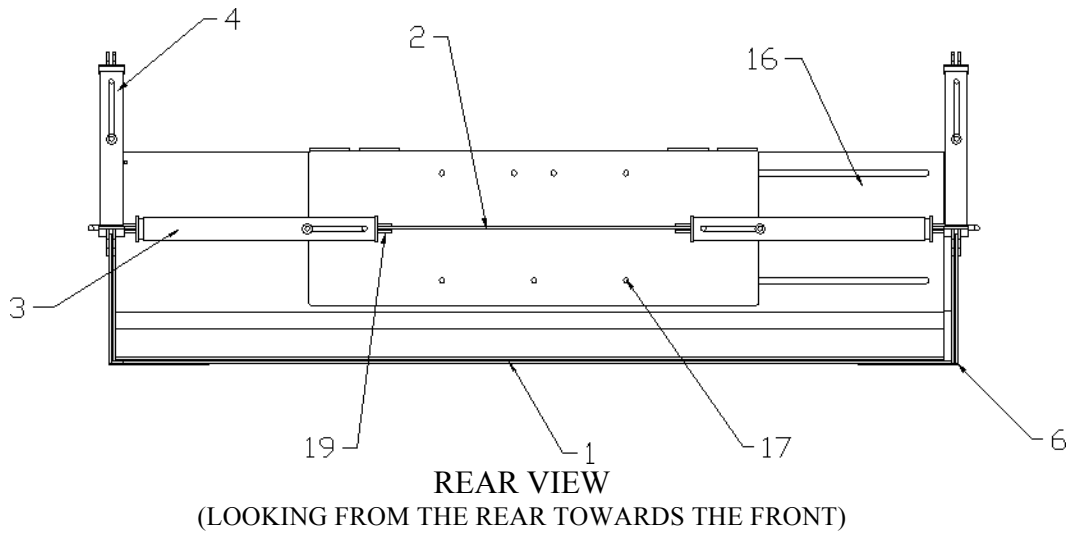
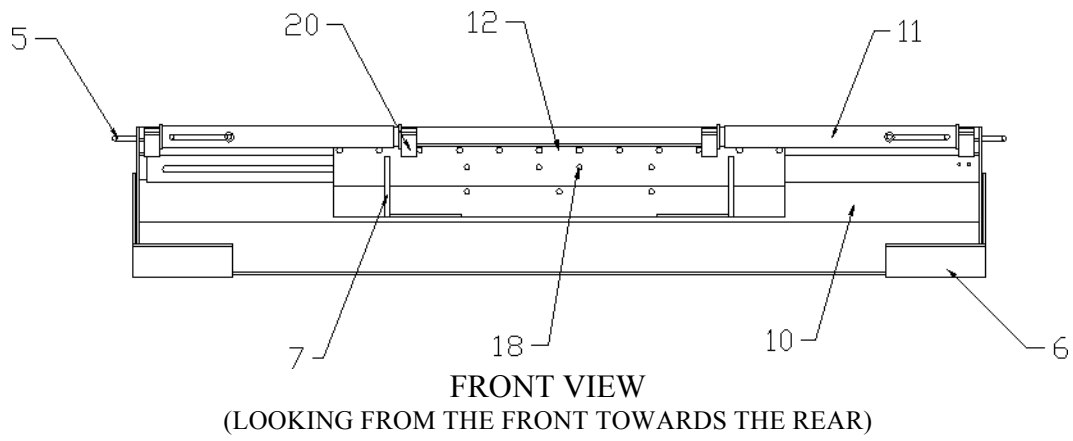
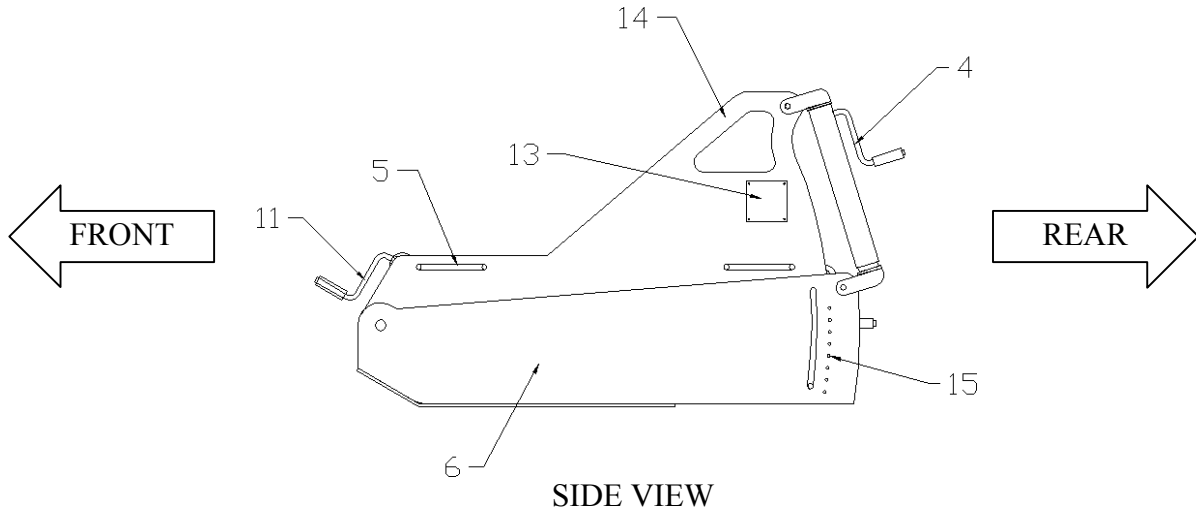

PART LIST & DESCRIPTION
CONTRACTORS MODEL 7' TO 12'
MATERIAL SPREADER

- 1 SCREED – Designed as an operators’ walkway at the rear of the spreader. It can be adjusted from 0” to 8” using (#4) LIFT JACK to set the thickness of the material being spread.
- 2 JACK ADJUSTMENT BAR, REAR – this bar with adjustment holes is a mount for the adjustable end of the (#3) EXTENSION JACK, REAR. The many holes make it more convenient to find a close hole for the (#19) PIN, REAR EXTENSION JACK.
- 3 EXTENSION JACK, REAR – This manually operated Jack extends from 0” to 15”. The Left Side, Front & Rear, Extension Jacks and the Right Side, Front & Rear, Extension Jacks must be extended or retracted AT THE SAME TIME. The Left Side Extension Jacks may be operated independently from the Right Side Extension Jacks. This allows the operator to offset the material being spread to the Left Side or Right Side of the Vehicle being used to pull the Material Spreader, i.e. to form a berm for a road.
- 4 LIFT JACK – This manually operated Jack extends from 0” to 8”. This allows the operator to adjust the height of the screed on the left and/or the right side of the Material Spreader. See (#15) SCREED HEIGHT GAUGE.
- 5 SIDE HANDLE – These four handles are attached to the Side Plates of the Material Spreader. These handles are used by the operators to fine tune the position of the Material Spreader. This may be required to insert the attachment pins when it is being mounted to the vehicle prior to each use. It is NOT recommended to use this handle as a lifting point.
- 6 SKID – These wide plates slide on the ground to help prevent the Material Spreader from “Digging in” to soft ground during use. The thin design of the Skid allows for side by side pulls of material up to ¼” apart. These plates are replaceable.
- 7 TOW BAR – These parallel plates extend out from the front of the Material Spreader. They each have a hole for a 1” Clevis pin in the front end. This hole is used to attach the Material Spreader to the towing vehicle. The rear end of the bar has a slot to use as a chain lifting point during transportation of the Material Spreader.

- 8 LIFT BRACKET, REAR – This Bracket is used as a winch cable lifting point and a chain hook mount.
- 9 LIFT BRACKET, FRONT – See (#8) LIFT BRACKET, REAR
- 10 WIDTH ADJUSTMENT PLATES, FRONT – They are made as a matched set of overlapping and slotted plates. The plates are adjusted by loosening the four (#18) FRONT ADJUSTMENT BOLTS and cranking the (#11) EXTENSION JACK, FRONT. (See Extension Jack Rear for additional information)
- 11 EXTENSION JACK, FRONT – See (#3) EXTENSION JACK, REAR
- 12 JACK ADJUSTMENT BAR, FRONT – See (#2) JACK ADJUSTMENT BAR, REAR
- 13 IDENTIFICATION TAG – This Tag lists the Model and Serial Number of the Material Spreader. This information is required for ordering replacement parts and operation instructions.
- 14 REAR HANDLE – This Handle is used by the operators standing on the Screed. It is NOT recommended that this handle be used as a lifting point.
- 15 SCREED HEIGHT GAUGE – Each (#6) SKID has a set of eight holes on the side that help the operator set the thickness of the material being spread by aligning the desired hole with the (#1) SCREED. Each (#6) SKID can be set independently. This allows the operator to set a slope to the material.
- 16 WIDTH ADJUSTMENT PLATES, REAR – See WIDTH ADJUSTMENT PLATES, FRONT.
- 17 BOLT, REAR WIDTH ADJUSTMENT PLATE – These seven bolts must be loosened to allow the (#16) REAR WIDTH ADJUSTMENT PLATES to adjust. If the winch is used to lift up on the (#8) LIFT BRACKET, REAR slightly before tightening the bolts, a hump or “crown” will be created on the material being spread.
- 18 BOLT, FRONT WIDTH ADJUSTMENT PLATE – These four bolts must be loosened to allow the (#10) FRONT WIDTH ADJUSTMENT PLATES to adjust.
- 19 PIN, REAR EXTENSION JACK – These two pins are used to attach the adjustable end of the (#3) EXTENSION JACKS, REAR to the (#2) JACK ADJUSTMENT BAR, REAR
- 20 PIN, FRONT EXTENSION JACK - These two pins are used to attach the adjustable end of the (#11) EXTENSION JACKS, FRONT to the (#12) JACK ADJUSTMENT BAR, FRONT

Material Spreader & Hitch Components

This diagram shows a side and top view of the material spreader and the standard hitch components. The hitch components are shown assembled and mounted to the material spreader, but not mounted to the towing vehicle. The assembly, as shown below, is just one of the many possible variations. The bracket that mounts to the truck may be used as shown, or rotated and flipped as needed to fit the users truck and height requirements. The flat bars that attach the material spreader to the truck are shipped to the user a standard length but may need to be cut to position the material spreader correctly. Directions for mounting the brackets to the towing vehicle and locating the material spreader properly are detailed in the installation instructions.

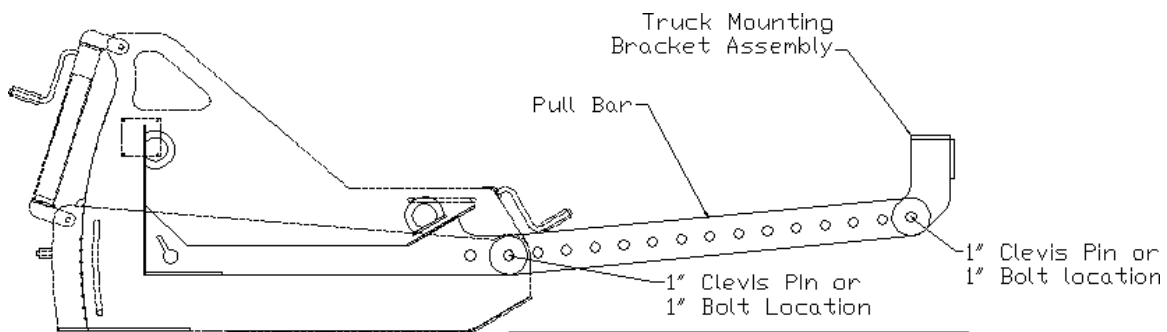

PULL BARS

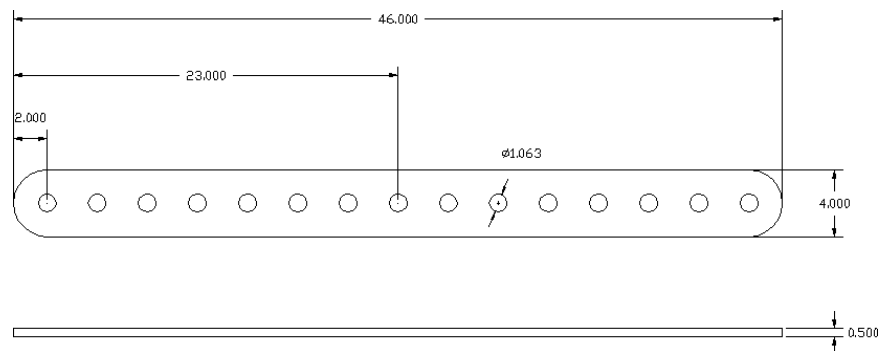

The Pull Bar (shown above) is one of a set of four required to attach the Material Spreader to the towing vehicle. The standard TRUCK MOUNTING ASSEMBLY will contain four pull bars that are 46" Long. This length should be longer than is required by almost all customers.

TRUCK MOUNTING BRACKET

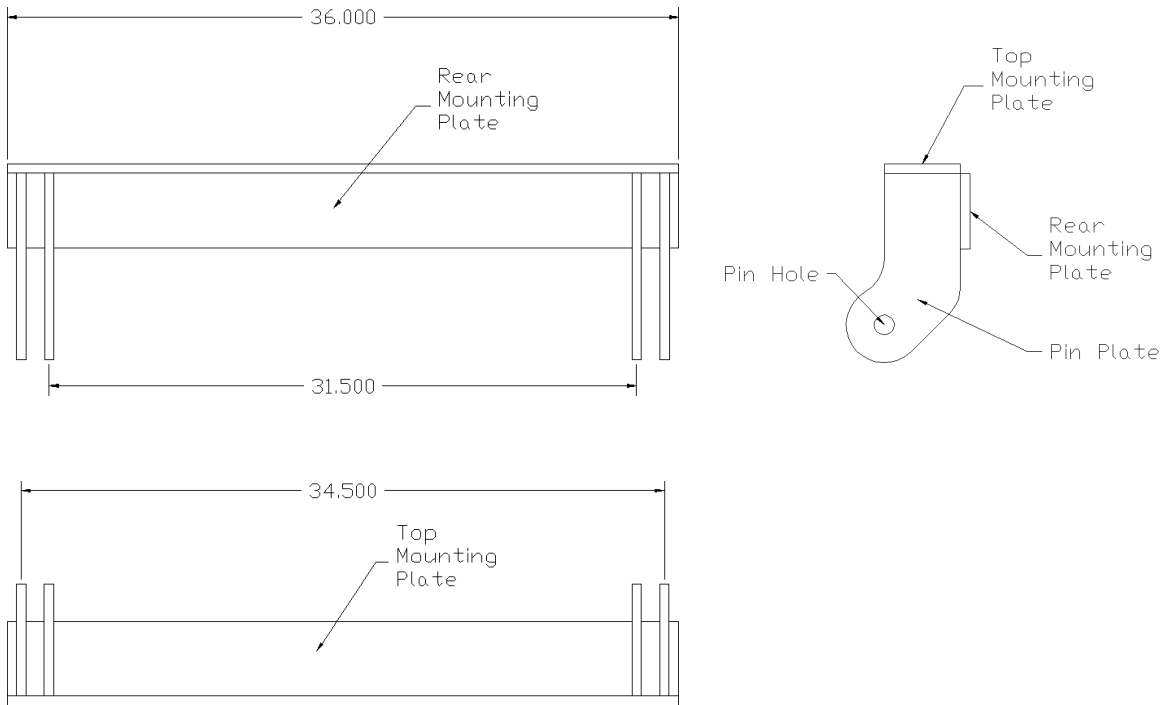

The TRUCK MOUNTING BRACKET shown above is a universal style mount designed to fit 90% of the dump trucks used. This bracket is mounted under the rear of the dump truck. The instructions on mounting this bracket are located in the INSTALLATION MANUAL.