

DRAG-A-BOX  
BRAND  
MATERIAL SPREADERS

MODEL CE 7-12

INSTALLATION MANUAL

BY  
J. PYOTT & ASSOCIATES

## Truck Bracket Assembly Mounting Instructions

The Truck Mounting Bracket is designed to mount at the rear of the towing vehicle, below the frame and behind the rear axle. The Mounting Bracket should be attached to that the center of the Pin Hole in the Pin Plate is 12" above the ground. The Truck Mounting Bracket Assembly should be turned so that one of the Mounting Plates faces upwards towards the truck frame, and one Mounting Plate faces toward the front of the truck. The Bracket Assembly needs to be mounted as close to the rear truck axle as possible without interfering with its safe action and full range of motion.

The Truck Mounting Bracket Assembly can be turned in a Vertical or Horizontal position. The difference in the mounting positions is only to make installation more universal. Most vehicles will have the Bracket Assembly installed in the vertical position to decrease the amount of fabrication required to lower the mount to the proper height. The optional horizontal position is for the occasional instance where obstructions under the truck frame leave less room for installation of the Mounting Bracket.

These instructions assume the towing vehicle is unloaded at the time of installation of the mounting brackets AND will be loaded with a spread able material that will lower its ride height approximately 4" when in use. Adjust the measurements as needed.

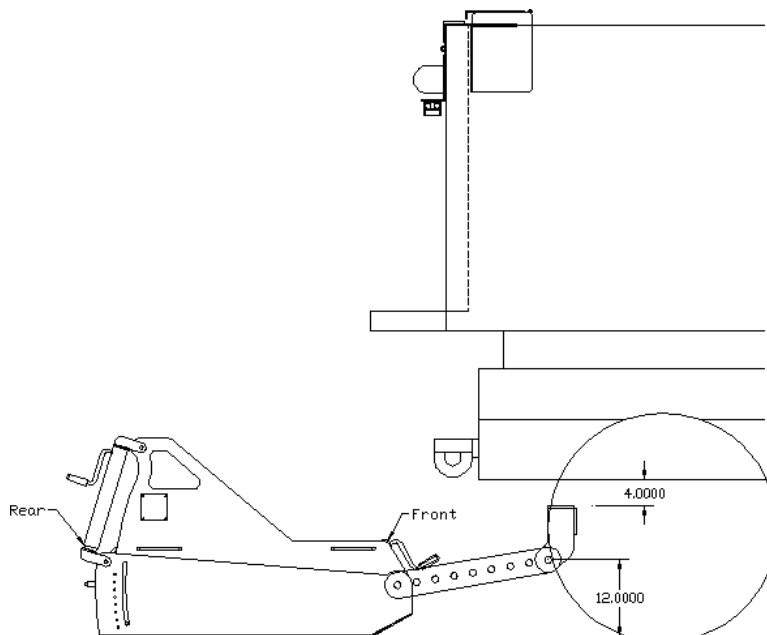

FIGURE 1

### INSTRUCTIONS FOR FIGURE 1

- Purchase about ½ ton of gravel or sand, and load it into the towing vehicle.
- Place the towing vehicle on flat and level ground
- Position the MATERIAL SPREADER behind the towing vehicle. Take a best guess at placing it properly using the included pictures and the knowledge you have of your truck.
- Dump a small amount of material in the MATERIAL SPREADER and raise the bed. When in use, the material leaving the bed must fall nearly in the center of the MATERIAL SPREADER. Move the spreader (or the truck) until the material lands properly. Take measurements to center the spreader behind the towing vehicle.

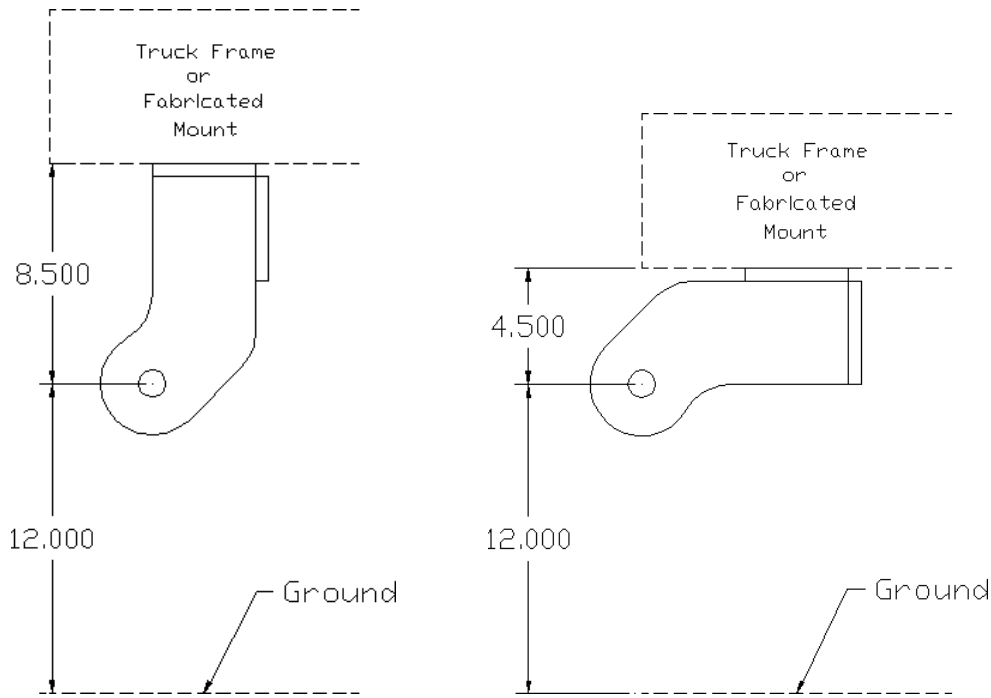

FIGURE 1-A

FIGURE 1-B

- The TRUCK MOUNTING BRACKET needs to be mounted as close to 12” from the ground to the center of the pin hole as possible. Mounting the bracket lower may not give the truck enough ground clearance. Mounting the bracket higher may cause the Material Spreader to “Lift” when you pull out, greatly reducing the surface quality of the end product.
- The TRUCK MOUNTING BRACKET is designed so that it can be mounted in two different positions (see FIGURE 1-A and 1-B). This

gives the installer a little extra flexibility and lets the bracket work with a larger number of trucks.

- Place a large floor jack under the TRUCK MOUNTING BRACKET. Use this floor jack to lift and hold the bracket into position.
- Measure the distance from the top of the TRUCK MOUNTING BRACKET to the bottom of the truck frame. You will be required to fabricate a custom bracket that will weld or bolt between the towing vehicles frame AND the TRUCK MOUNTING BRACKET. Follow all of your vehicle manufacturers' requirements when attaching accessories to your truck frame. Serious damage can result from improper modifications to your vehicle.
- In this example, the distance from the truck frame to the bracket is 4". (See drawing). A simple box made from 4" C-channel would be all that is required.
- Temporarily pin the PULL BARS to the TRUCK MOUNTING BRACKET and swing the PULL BARS up and down to make sure they do not interfere with anything on the vehicle such as air brake canisters, spring hanger brackets, and bumpers.
- With the MATERIAL SPREADER in place behind the truck, pin one end of a PULL BAR to the MATERIAL SPREADER and swing the other end up to align a hole in the PULL BAR with THE hole in the TRUCK MOUNTING BRACKET. Mark this hole.
- All four PULL BARS will need to be cut to the proper length so that the hole you marked is the last hole in the PULL BARS. Instructions for cutting the PULL BARS will be explained later in this manual.

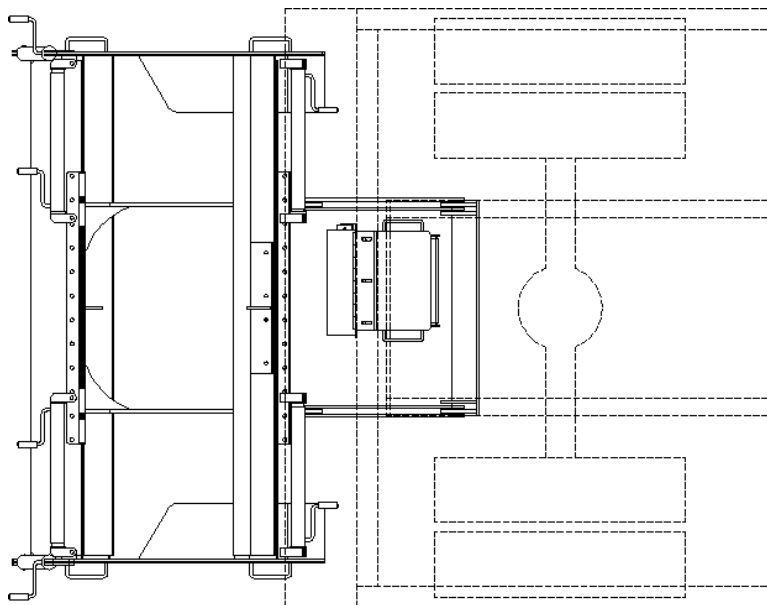

FIGURE 2

INSTRUCTIONS FOR FIGURE 2

- This overhead view shows the MATERIAL SPREADER mounted behind a truck with the hitch components and the MATERIAL SPREADER mounted in the proper position.
- Notice the position of the PULL BARS. The bars can be placed in different positions on the TRUCK MOUNTING BRACKET. Pinning the PULL BARS on the inside will put them at a slight angle. This will make the assembly more ridged.

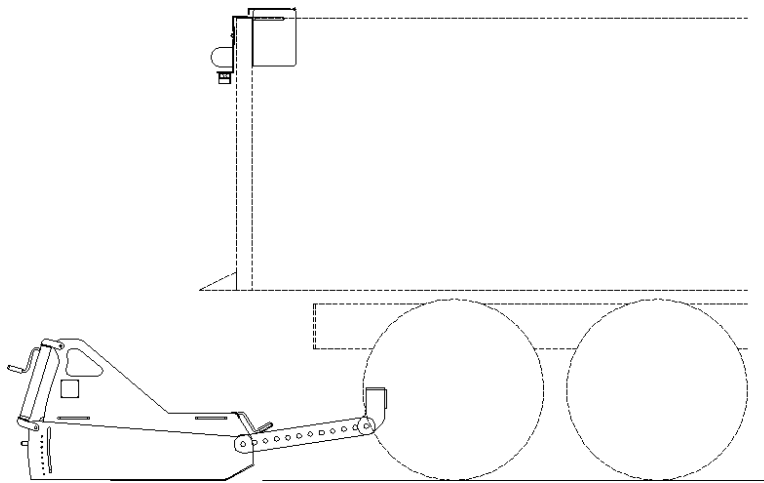

FIGURE 3

INSTRUCTIONS FOR FIGURE 3

- This is a diagram showing the MATERIAL SPREADER and the hitch components assembled to a Tandem Axle truck with a long rear overhang.
- Tandem Trucks are usually more complicated and a number of issues must be solved while installing the MATERIAL SPREADER.
- The rear suspension parts and brackets are more complicated and have a higher chance of being in the way of the best mounting location for the TRUCK MOUNTING BRACKET.
- The bed is longer and usually does not lift as high. This means that the material leaving the bed when it dumps is going at a higher speed and will dump farther from the rear of the truck, requiring the MATERIAL SPREADER to be positioned farther from the rear of the truck.

- Tandem trucks usually have a larger portion of the truck bed hanging past the rear axle. This means the PULL BARS will be longer.
- Take additional time installing the MATERIAL SPREADER in this situation so that the MATERIAL SPREADER Assembly will function properly and still be able to lift completely off of the ground for transport.

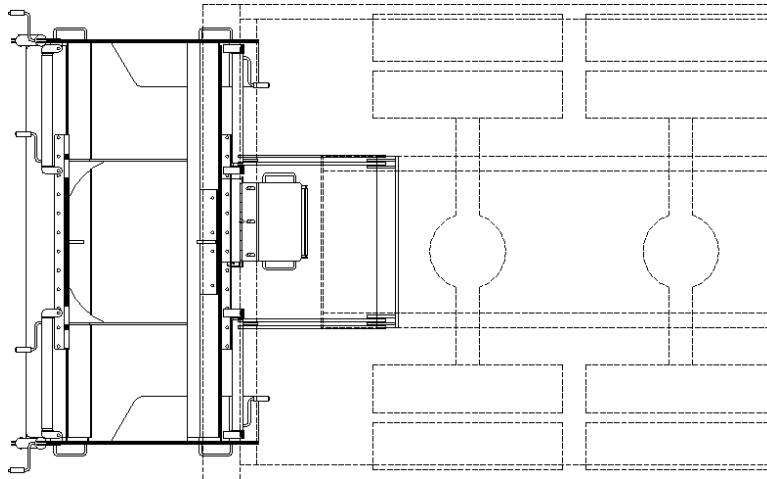

FIGURE 4

#### INSTRUCTIONS FOR FIGURE 4

- This overhead view of the Tandem Truck shows the relationship between the MATERIAL SPREADER, Hitch Components, and the Tandem Axles.
- Almost all aspects of the installation on a Tandem Truck are the same as those for a Single Axle Truck. Follow the instructions for a single axle truck; just be more careful in positioning the MATERIAL SPREADER so that the bed dumps material properly into the spreader.

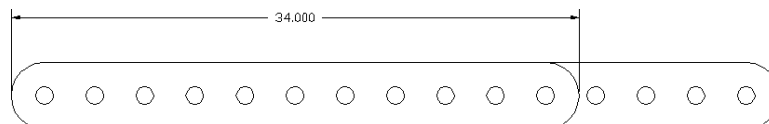

FIGURE 5

After following the instructions in FIGURE 1 to determine the proper length of pull bar required, do the following.

#### INSTRUCTIONS FOR FIGURE 5

Let us assume that an overall length of 34” is required to locate the Material Spreader properly. Use one of the other Pull Bars as a template to mark all of the Pull Bars by laying one bar over another, measure out the proper length, align the holes, and mark the new radius (see above). Then use a torch, chop saw, band saw, or other similar metal cutting device to cut the radius as closely as possible. Grind this end and paint it to prevent rust.

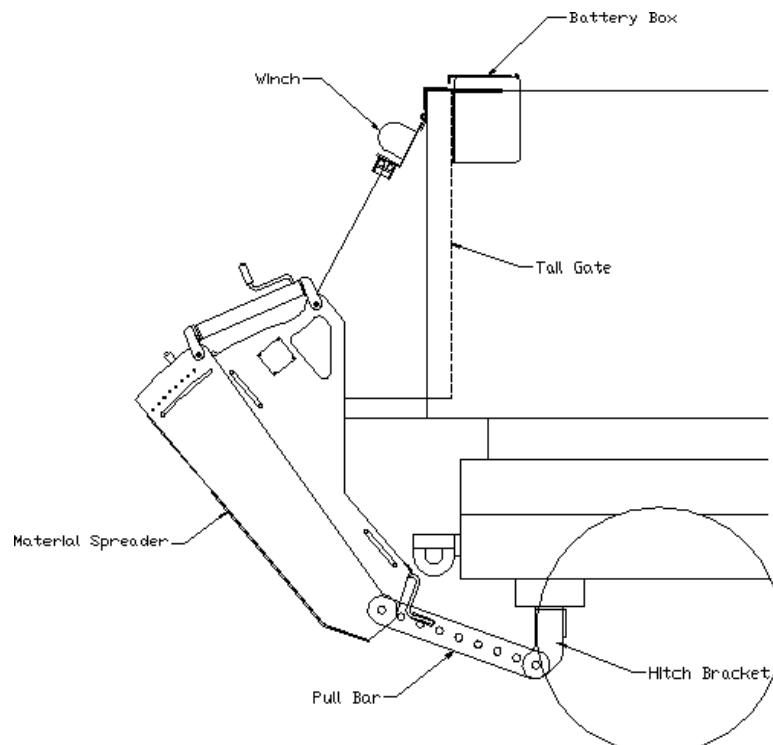

FIGURE 6

#### INSTRUCTIONS FOR FIGURE 6

- You should now have the TRUCK MOUNTING BRACKET attached to a spacer bracket you have constructed that holds the TRUCK MOUNTING BRACKET in the proper position.
- You should also have PULL BARS cut the proper length to hold the MATERIAL SPREADER in the position behind your truck that material dumps into it properly.
- The Battery Box and Lift Plate Assembly “Hangs” over the top edge of the truck tailgate. The assembly adjusts to fit the thickness of most tailgates by sliding the front and rear halves together and tightening them with the T-bolts.

- This Assembly is heavy. Care should be used when lifting heavy objects. It is recommended that the battery be installed after placing the assembly on the tailgate.
- The winch is not a hoist and is not meant to be used for overhead lifting. No one should be on, under, or near the Material Spreader while the winch is in use. Always keep the spreader safely chained in position whenever people are working on or adjusting the Material Spreader.
- Attach the hook on the winch cable to the lifting lug on the inside of the front of the Material Spreader. Use the winch to lift the front of the Material Spreader off of the ground and chain this end of the spreader to the bed of the truck. You will need to attach a chain hook to your bed on each side if you do not already have one. Re-attach the winch cable hook to the lifting lug on the inside of the rear of the Material Spreader and finish raising the Material Spreader off of the ground. Complete the lifting process by chaining the rear of the Material Spreader to the bed of the truck (see above). Remove tension from the winch cable. The spreader is now ready to transport behind the truck.